

2.5" SSD

ISSS332 PLP Edition



The ISSS332 PLP (Power Loss Protection) industrial-grade 2.5" SSD is equipped with MLC NAND flash to provide a 3K P/E cycle rating for long-lasting durability. What's more, with PLP (Power Loss Protection) these SSDs guard against data loss when a sudden power failure occurs, and also uses tantalum polymer capacitors with short circuit protection mechanism. Other valuable features include DRAM Buffer for improved IOPS and read and write, and ECC error correction technology for data accuracy and integrity. The ISSS332 PLP has high compatibility and is suitable for industrial PCs, embedded devices, automation, networking, and transportation applications.

Features

- Power Loss Protection (PLP)
- Tantalum Polymer capacitors with short circuit protection mechanism
- 3K P/E cycle rating for excellent durability and reliability
- Wide temperature support: -40°C to 85°C
- DRAM Buffer included
- BCH ECC error correction
- Suitable for industrial PCs, embedded devices, automation, networking, and transportation

Ordering Information

Operating Temp.	32GB	64GB	128GB	256GB	512GB	1TB
0°C to 70°C	ISSS332-032GMP	ISSS332-064GMP	ISSS332-128GMP	ISSS332-256GMP	ISSS332-512GMP	ISSS332-001TMP
-40°C to 85°C	ISSS332-032GTP	ISSS332-064GTP	ISSS332-128GTP	ISSS332-256GTP	ISSS332-512GTP	ISSS332-001TTP

Specifications

Model	ISSS332 PLP
Form Factor	2.5"
Capacity	32GB – 1TB
Interface	SATA III
Flash Type	MLC
Dimensions (L x W x H)	100 x 70 x 7mm
Sequential Read (Max.)	560MB/s
Sequential Write (Max.)	440MB/s
Operating Temperature (Standard)	0°C to 70°C
Operating Temperature (Industrial)	-40°C to 85°C
Operating Voltage	5V
Power Consumption (Max.)	3.5W
Shock Resistance	1500G/0.5ms
Operating Humidity	5%-95 RH, non-condensing
Vibration Resistance	20G (20-2000Hz)
Technologies	Power Loss Protection, BCH ECC, Wear Leveling, DRAM Buffer TRIM and NCQ command, S.M.A.R.T. Monitor

Diagram

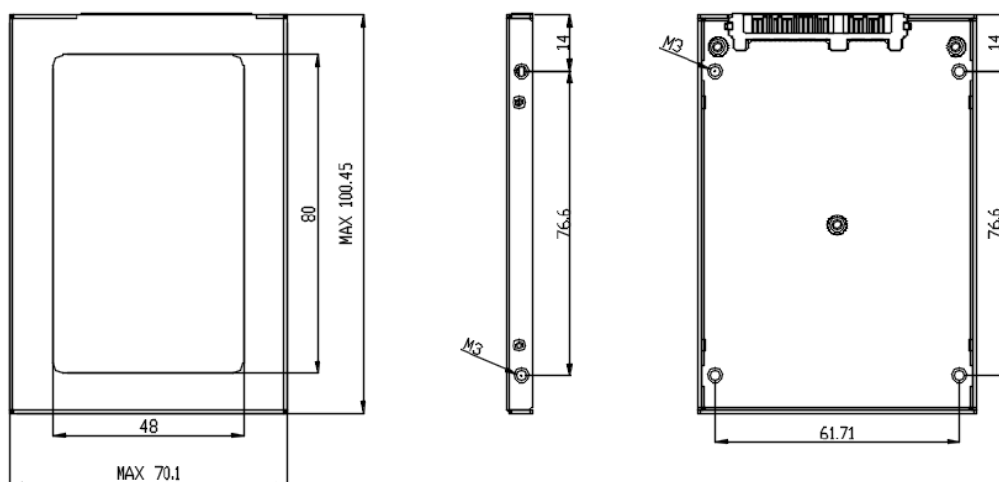

Unit: mm

Contact Us

HQ (Taiwan):

T: +886-8228-0886

E: IA_Global@adata.com

US:

T: +1-714-332-8708

E: IASales_us@adata.com

EU:

T: +49-899-0405-296

E: IASales_eu@adata.com

China

T: +86-21-6233-1010

E: IASales_cn@adata.com

JP:

T: +81-3-5807-0011

E: IASales_jp@adata.com

APAC/MEA:

E: IASales_apacmea@adata.com